

Troubleshooting Guide

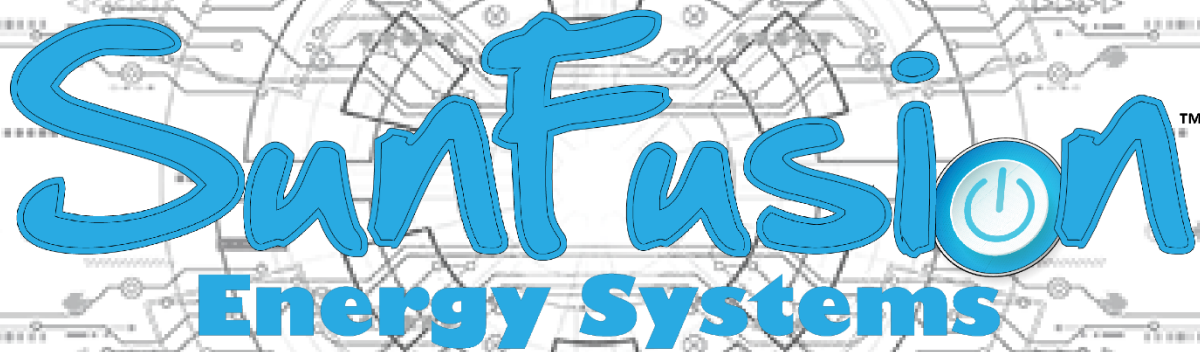

SunFusionTM
Energy Systems

1.800.544.0282

Info@sunfusioness.



9020 Kenamar Dr Suite
204, San Diego CA. 92121

Table of Contents

Introduction to Troubleshooting.....	1
Tools Needed	2
Rapid Shut down.....	2-3
Rapid Start Up	4-5
Wi-Fi Start Up.....	5
AC Power Out Testing.....	6-7
Solar Testing.....	8
Battery Testing.....	9-10
Full System Diagram.....	11
AC Power Diagram.....	12
Solar Diagram.....	13

Read Before Proceeding

Before we start trouble shooting. It is important for the homeowner to understand our system. Our batteries are fully equipped cells that are Lithium-iron Phosphate. Each battery contains large format prismatic cells. Every homeowner has a cabinet specially customized for their needs. To put this in perspective, a homeowner with an electric car, well-pump, electric equipped appliances, and a heated pool will need more Kilowatts per hour compared to someone with electric equipped appliances, refrigerator, microwave, lighting, and no heavy loads.

Please do not overload your system and understand how many Kilowatts your system can use so it is not overloaded. If you experience a brown or blackout during backup operating, reduce the load, and check to make sure the load breakers are not open.

Note: Weather will have a direct effect on the cabinet.

On cloudy days, the strength of the UV rays will be significantly less powerful compared to a clear sky day. This is the same concept for days with morning haze, nighttime, snowy days, or any weather condition that does not allow UV rays to properly permeate the solar panels. Rainy days will have the same effect as cloudy days; however, Rainy days will help clean off the panels from dirt and dust build-up. If heavy loads are being used during these times, then the utility grid will compensate for the excess use of electricity. If you do not operate with the grid, then your back-up generator will compensate. If you do not operate with the utility grid or a generator, then your battery will drain, and you will be without power until the battery can charge up again.

In situations where the power is off for several days, it is important to be diligent with electricity. We recommend turning off appliances that are not for essential use. If there are several days of cloudy skies, be aware of where you are running electricity. The duration of the battery will last longer if the correct precautions are taken.

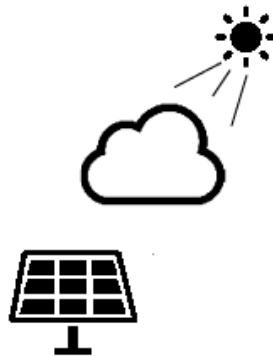

- If panels have not been cleaned in a while, there is a possibility dirt, dust, snow, or anything blocking the sun's ability to penetrate the panels needs to be cleaned off.

Rapid Shut Down

If the system is still not functioning properly, you will need to test it. You will need an impact or nut drive (3/8ths or 5/16ths) and a multimeter.



3/8 Nut Driver



5/16 Impact Driver



⚠ WARNING: Take caution opening the dead-front cover inside the Echo. Exposed wiring can present a risk of electrical shock. Only do this if requested by SunFusion.

The first steps are simple. Locate the Transfer Switch, In the up position its in Battery mode, if the handle is in the middle its off no power to LOAD, if handle is down it will use the Utility. Make sure while trouble shooting the Transfer Switch is in Utility only so handle is down.

Please turn off your entire system inverters and batteries. This requires removing the battery dead front, please reference the diagram on page 11 to do this. Refer to numbers 5 and 10.



At the top of the Cabinet look for the SunFusion logo, located near the far left between the I and N, press the power button. Make sure the button turns off by looking to see if the light is active.



Next, turn off all batteries by pressing the power button off and flipping the breaker switch downward indicating it is off.



 **CAUTION:** Busbars maybe live still when the 250-amp breaker switch is off. Take caution around it, for it will electrocute you.

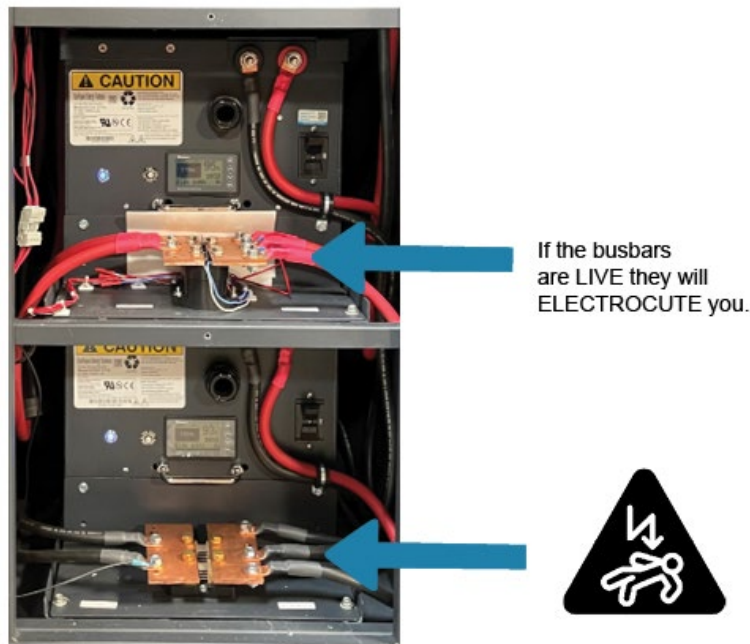

Disconnect AC Plug in. Disconnect the Solar plug in

Rapid Start Up

Leave everything unplugged for 2 minutes to let the system completely shut down. Then go ahead and grab your quick start guide for reference as well. We are going to go through an entire start up and testing of your system.

At the top of the Cabinet look for the SunFusion logo, located near the far left between the I and N, press this button, and the system will light up meaning it is active.

Check all batteries. Make sure to press the power button, it will light up if it is active, and the breaker switch is in the upward direction, indicating the system is on. The LED display will light up as well indicating it is on.

 **CAUTION:** Busbars are live when the 250-amp breaker switch is on. Take caution around it, for it will electrocute you.



If the busbars are LIVE they will ELECTROCUTE you.



Plug the AC connect back in and connect the Solar plug back in

After about a minute, the red light on the Wi-Fi dongle stick will light up. This indicates the inverter is turning on and connecting to your network.

Check the Wi-Fi dongle for the red and green lights to confirm the inverter is active. If the green light is not on you will need to check page () for network trouble shooting.



If this is a new installation the dongle needs to be programmed to the Wi-Fi system this is for all dongles in the system. Please refer to the quick start guide on pages (20-23).

Your system should now be fully operating and reset. The next portion you will now need your multimeter. Here we will start testing.

AC Power Testing

During testing, we will be measuring AC power out and solar voltage. AC power out is important to check because it lets the homeowner know if the inverter is on and properly running. It is important to check the solar voltage because it will tell the homeowner if the system is receiving the power needed to run the system.

Most of the time the Sol-Ark inverter will let you know if there is a fault. It does this by beeping and exposing a red light on the system.



WARNING: If the inverter beeps there is a fault check for the red light on the inverter. Use the long mirror provided or use your phone to take a picture of the screen. Please reference the Sol-Ark Installation and Owner's manual pages (37-39).

A red light will flash here to indicate there is a fault with the inverter.

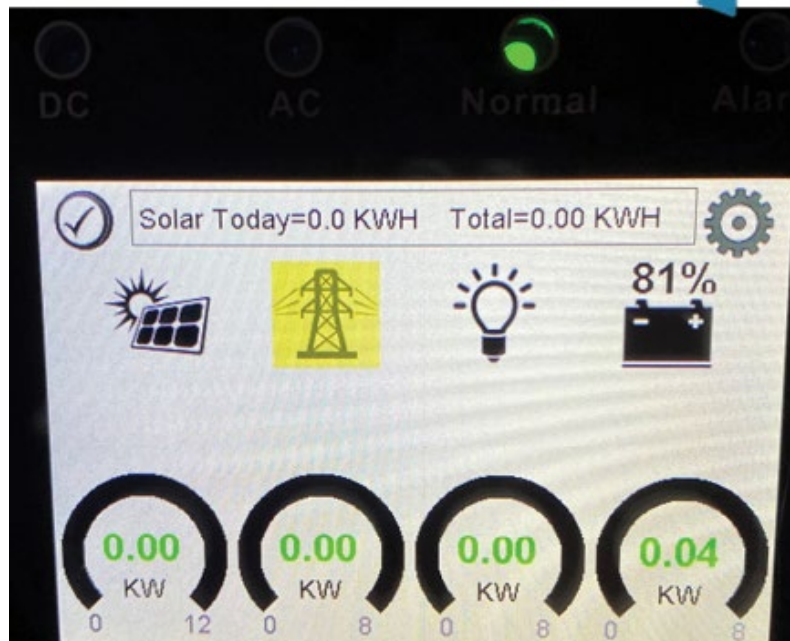

AC power is simple to check on our system. Take your multimeter and set it to V~.



CAUTION: NEVER cross polarities. Make sure you test Red to Red (positive to positive) and Black to Black (negative to negative) ALWAYS. This could ruin the system if polarities are crossed.

The far most left ports on the AC connector are the ports the homeowner will need to test for AC power out. Remember DO NOT cross polarities. Match the red prong to the red wire insert and the black prong to black wire insert. As shown in the photo. The multimeter should read 120/240.

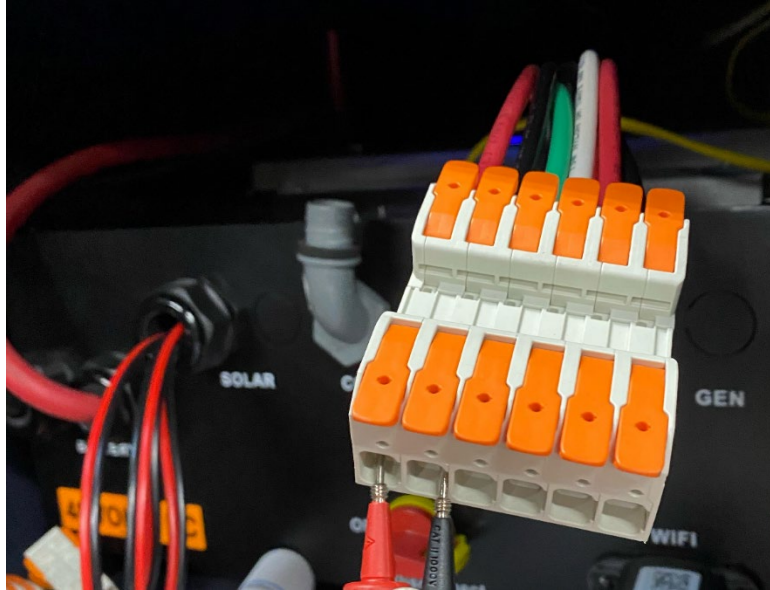

If it does not read accurately, please call 1-800-544-0282 or email us at info@sunfusioness.com

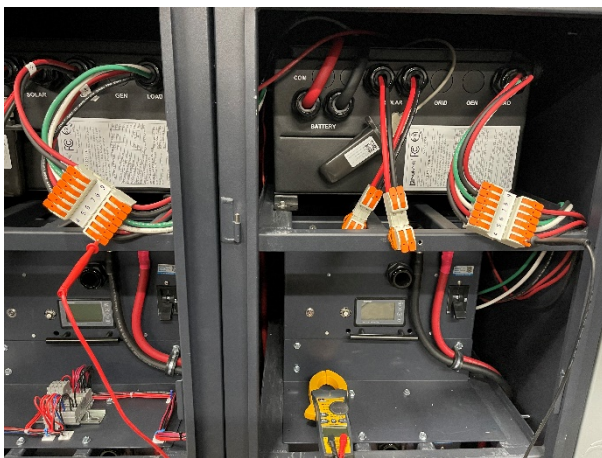

Note: The above photos number to number will read zero, if 240V or your voltage you are cross phased and need to locate at the sub-panel breaker make sure your lines are not cross phased inverters are temperamental.

Solar Testing

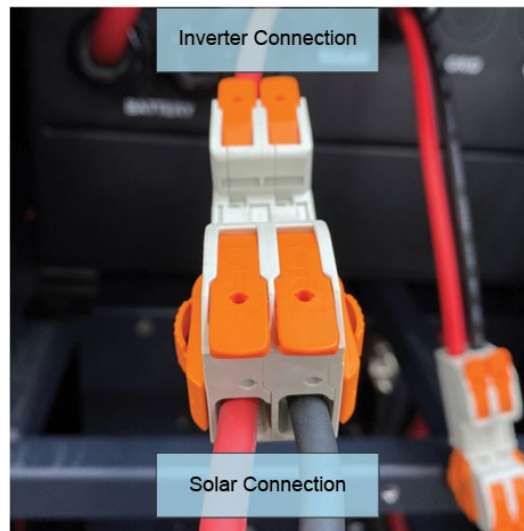

Next we will be testing solar voltage. Use the multimeter and set it to V_{DC} . Test positive to positive. Test Negative to Negative. You want the meter to read under 550V.

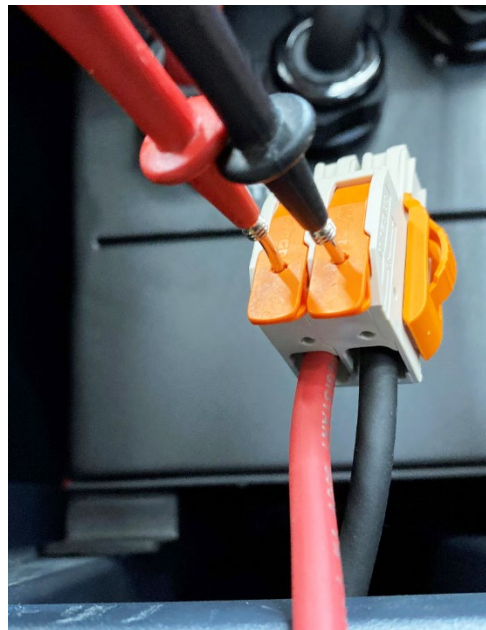

If it does not read accurately, please call 1-800-544-0282 or email us at info@sunfusioness.com

Battery Testing

To finish up testing, we will need to test the batteries. These are the reason homeowners are able to stay off grid and power their homes. In order to test these, we must be extremely safe and shy away from touching any electrical wires.

For this next part, turn off the 250AMP breaker switch. We will begin testing the batteries to check and make sure the voltage for each battery is correct.



Switch breaker
in the downward
direction, before
testing.



CAUTION: Busbars maybe live still when the 250-amp breaker switch is off. Take caution around it, for it will electrocute you.

Take the multimeter and set it to V_{DC} . Test the red prong to the red busbar. Test the black prong to black busbar.

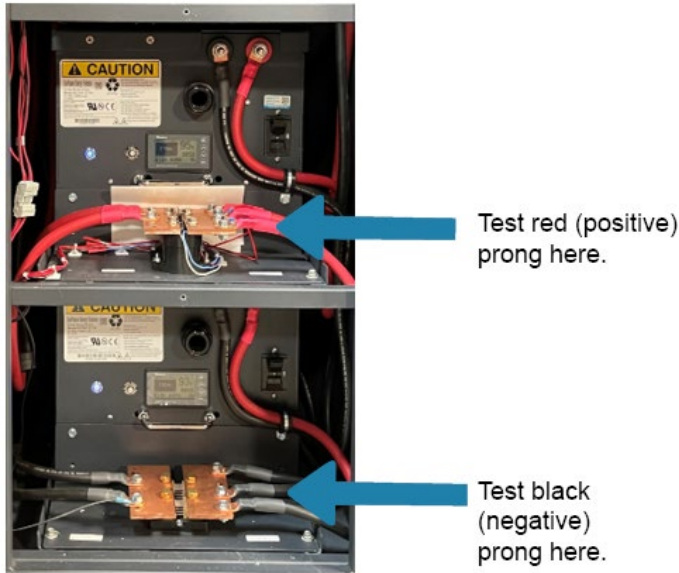

The voltage for each battery must read the same number or be within 5-tenths of a volt. For example, this battery reads 52.3v. This means the other batteries must range between (51.9v - 52.8v). Please refer to the picture.

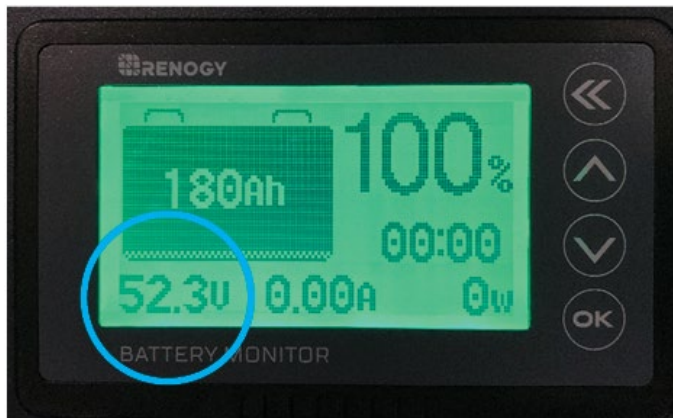

If the DC voltage reading, from the multimeter, does not match the battery DC requirement from the LED display, leave the battery pack on for 48 HOURS to let the system set and batteries equalize before house use.

If it does not read accurately, please call 1-800-544-0282 or email us at info@sunfusioness.com

Full System Diagram

- 1) Rapid Shut Down
- 2) Network Parallel
- 3) Solar 500V Max 13.5kW 4 Strings Max
- 4) AUF-2/0 Red, Black, AMP rating to 304 AMPS
- 5) Battery Area
- 6) Battery Terminals
- 7) Battery Box
- 8) 250A DC Breaker
- 9) LED Display
- 10) Battery Dead Front
- 11) Locking Door
- 12) Inverter Area
- 13) Power Button
- 14) 3A Fuse

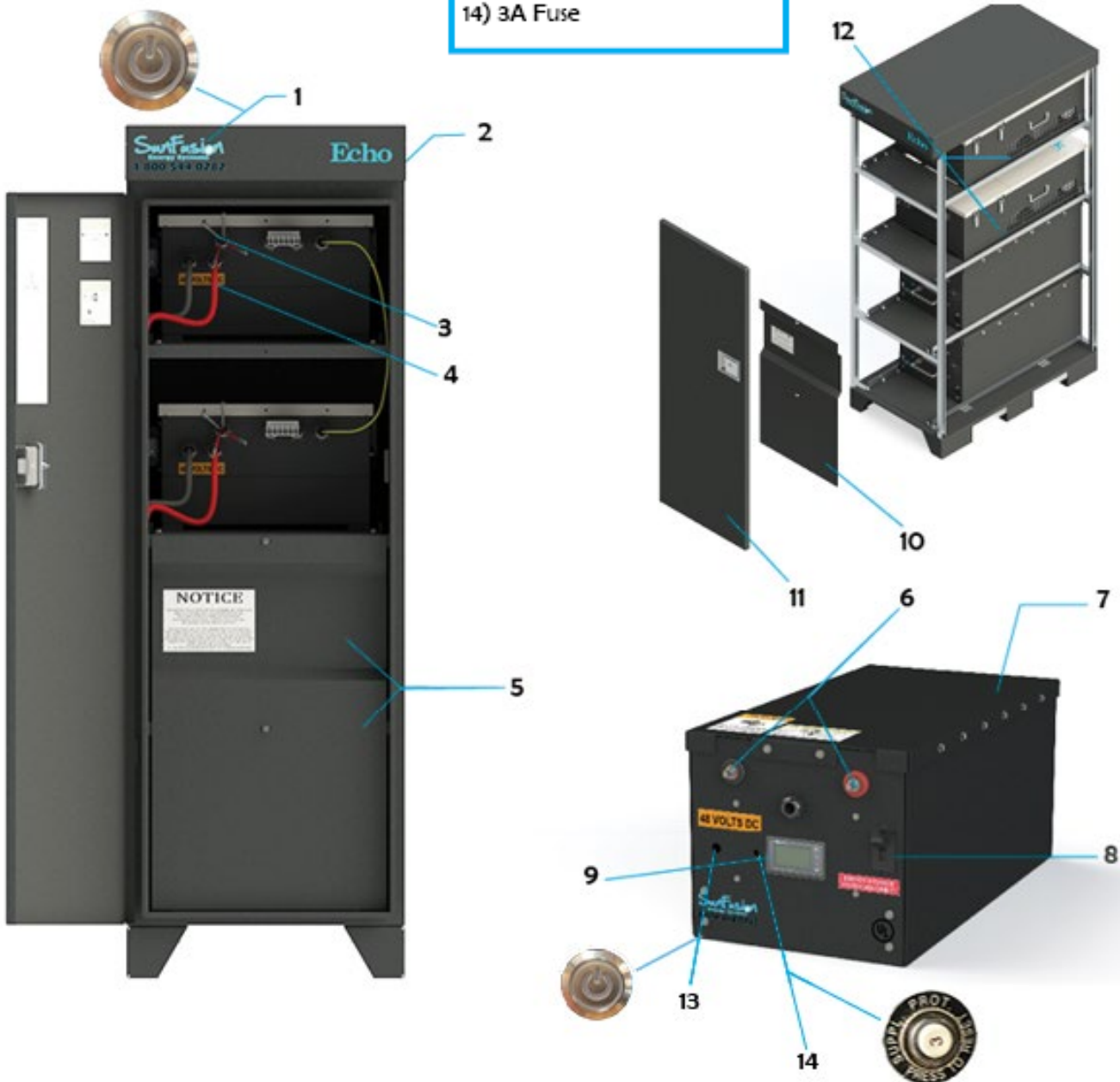

AC Power Diagram

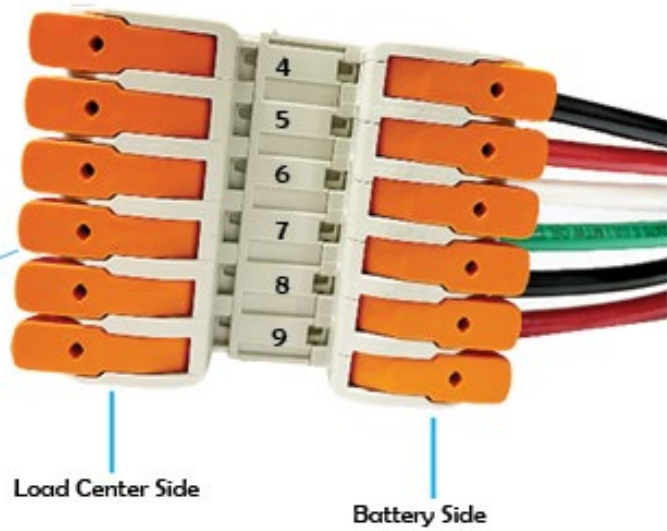

- 4) AC-Out Battery
- 5) AC-Out Battery
- 6) Neutral
- 7) Ground
- 8) AC-In Utility
- 9) AC-In Utility

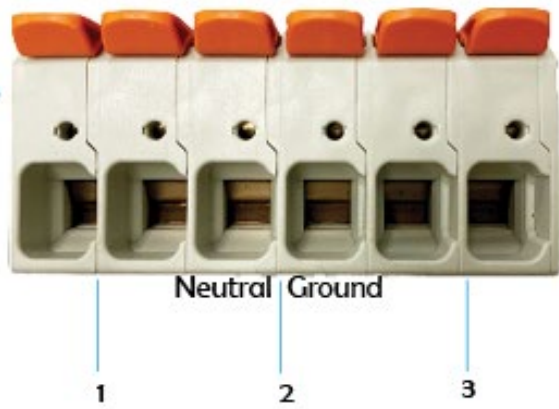

- 1) Battery out 120/240 AUF-8 Red, Black, AMP rating 83 AMPS (load or critical load out)
- 2) Utility in 120/240
- 3) Grid In 120/240

Solar Diagram

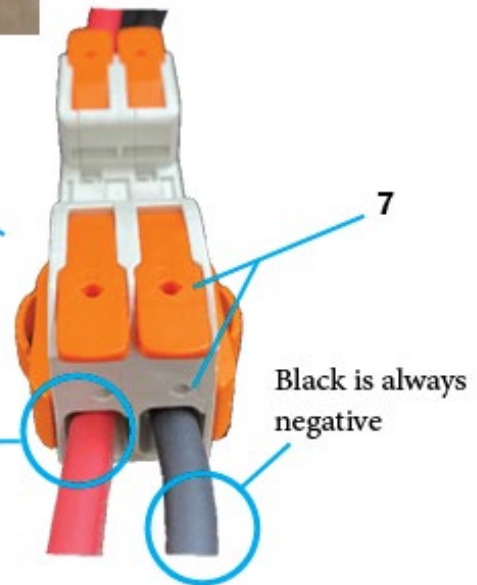
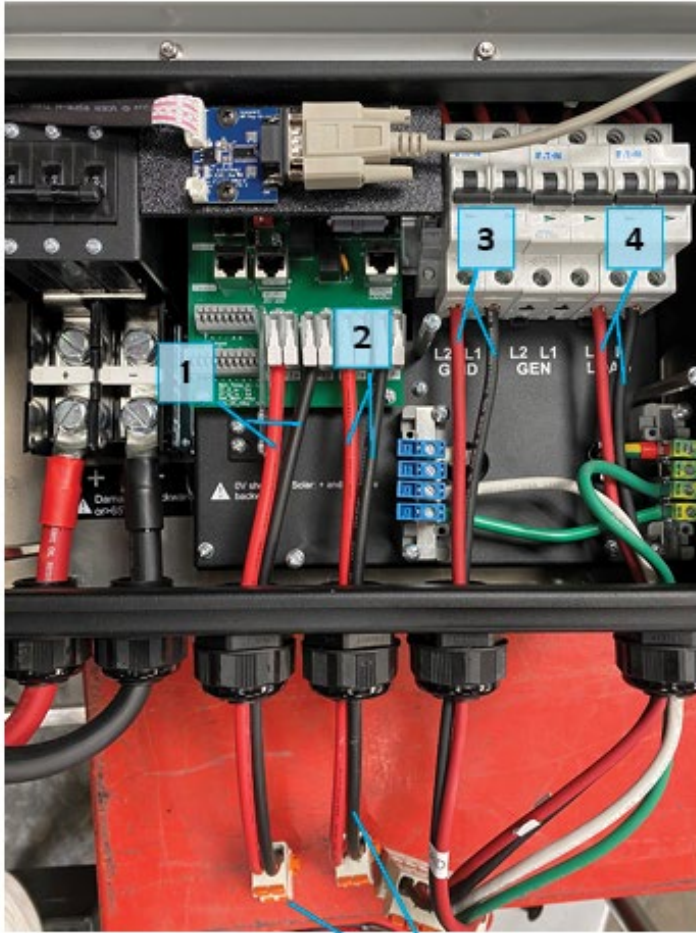

- 1) PV 1
- 2) PV 2
- 3) Grid In
- 4) Load Out
- 5) Inverter Connect
- 6) Solar Connect
- 7) Testing Ports